

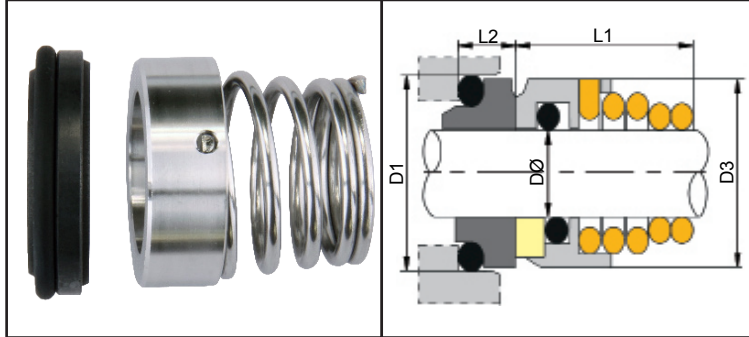

VULCAN® SEALS TO SUIT GRUNDFOS® HILGE® PUMPS

CONICAL SPRING SEAL TYPES

Vulcan manufacture and stock a wide range of conical spring seals to suit several Grundfos® Hilge® centrifugal pump ranges, such as Hygia®, Maxana® and Sipla®. To aid identification of these very similar looking seals, please use the table below as your guide, showing the installed dimensions with the Vulcan Type code and the O.E.M. Type code.



Vulcan's Stock Code Example
Please replace XXXX with the size code and YY with the relevant Vulcan Type code.
W-XXXX.YY.R.E.P.

Type YY, as per Vulcan Type Code shown below, with clockwise coil, Stainless Steel vs Carbon, and E.P. elastomer.
W-XXXX.YY.R.E.S.

Type YY, as per Vulcan Type Code shown below, with clockwise coil, Silicon Carbide seal faces, and E.P. elastomer.

SHAFT SIZE DØ	SIZE CODE	D1	D3	L1	L2	VULCAN TYPE CODE	O.E.M. SEAL CODE	GUARANTEED STOCK MATERIALS
19.00	0190	30.90	31.00	25.00	8.00	12	001-19 O3	EV PS 316 FDA
19.00	0190	30.90	31.00	25.00	8.00	12S	001-19 O5	EV PS 316
19.00	0190	35.00	31.00	20.00	9.50	8BU	002-19 O3	EV PS 316
22.00	0220	37.00	33.00	27.50	10.00	126	L1K-22 F3	EV PS 316 FDA
28.00	0280	43.30	40.00	29.00	9.00	12	001-28 O3	EV PS 316 FDA
28.00	0280	43.30	40.00	29.00	9.00	12H	001-28 A3	EV S 316
28.00	0280	43.30	40.00	29.00	9.00	12S	001-28 O5	EV PS 316
28.00	0280	42.00	40.00	24.60	11.00	8B	002-28 O3	EV P 316
30.00	0300	45.00	43.00	32.50	10.00	126	L1K-30 F3	EV PS 316 FDA
30.00	0300	45.00	43.00	32.50	10.00	126L	L1K-30 G3	EV S 316
30.00	0300	45.00	43.00	40.00	10.00	127	L1N-30 D3	EV PS 316
38.00	0380	60.50	53.00	39.00	11.50	12	001-38 O3	EV PS 316 FDA
38.00	0380	55.00	53.00	31.00	11.50	8B	002-38 O3	EV P 316
40.00	0400	58.00	56.00	34.00	13.00	126	L1K-40 F3	EV PS 316 FDA
40.00	0400	58.00	56.00	34.00	13.00	126L	L1K-40 G3	EV S 316
50.00	0500	70.00	66.00	38.00	14.00	126	L1K-50 F3	EV P 316
50.00	0500	70.00	66.00	38.00	14.00	126L	L1K-50 G3	EV S 316
50.00*	0500	70.00	66.00	43.00	14.00	8BU	1238-50 O3	EV P 316

If the final digit of the O.E.M. seal code is "2" then the replacement seal requires an anti-clockwise rotation coil. Please replace the "R" character in the Vulcan code with "L" for anti-clockwise coil. If the O.E.M. code you require is not listed, check the two seal types following or please contact us with your requirements.

TYPE 128 EV P R 316

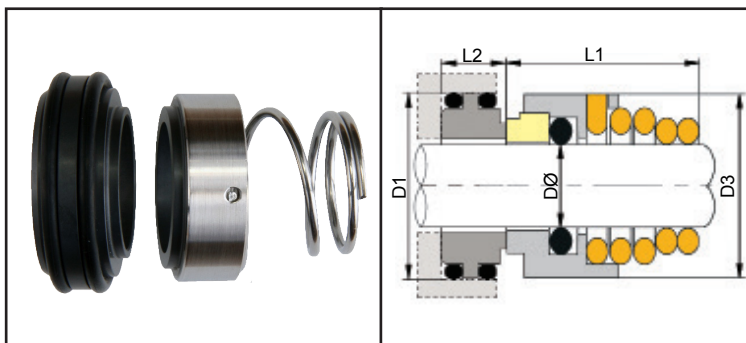

Vulcan manufacture and stock our Type 128 conical spring seals with bi-elastomeric seats, for pumps with flushed seal chambers.

The Type 128 is frequently installed in tandem with the Type 12 seals listed above, on Grundfos®, Hilge® centrifugal pumps.

SHAFT SIZE DØ	SIZE CODE	D1	D3	L1	L2	O.E.M. SEAL CODE
19.00	0190	39.30	31.00	20.00	17.50	0B3-19 B3
28.00	0280	47.30	40.00	26.50	18.00	0B3-28 B3
38.00	0380	59.30	53.00	33.50	16.80	0B3-38 B3



VULCAN® SEALS TO SUIT GRUNDFOS® HILGE® INOXPA® AND JABSCO® PUMPS

HYGIENIC 1662/1663 SEAL TYPES

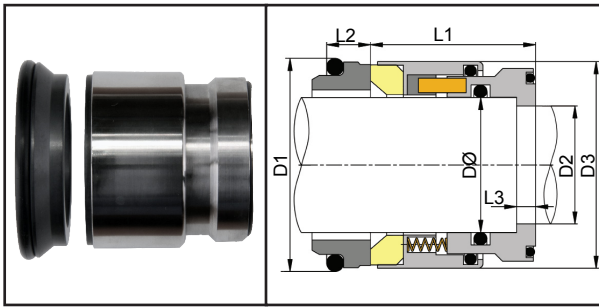

Vulcan manufacture and stock multi-spring seals to replace the original O.E.M. wave-spring seals, utilised for hygienic applications in Grundfos® Hilge® centrifugal pumps.

The common centrifugal series includes; Hygiana®, Euro Hygia®, Maxana®, Dura®, Sipla®, Contra® and Durietta®. However, the seal codes are universal and you may identify your seal from the codes below.

Conversion to the direct replacement Vulcan balanced multiple-spring design avoids the potential for premature single wave-spring failure.

SHAFT SIZE DØ	SIZE CODE	D1	D2	D3	L1	L2	L3	VULCAN TYPE CODE	O.E.M. SEAL CODE	GUARANTEED STOCK MATERIALS
19.00	0190	30.90	16.00	33.50	29.00	8.00	4.00	1662	001-19 O1	EV CS R 316 FDA
28.00	0280	43.30	24.00	43.00	33.00	9.00	4.00	1662	001-28 O1	EV CS R 316 FDA
28.00	0280	43.30	24.00	43.00	33.00	9.00	4.00	1662L	001-28 A1	EV R 316 FDA
28.00	0280	48.00	24.00	43.00	34.50	10.50	0.50	1663	BS2-28 O1	EV CS R 316
28.00	0280	48.00	24.00	43.00	38.00	10.50	4.00	1663A	BS3-28 O1	EV CS R 316
38.00*	0380	60.50	35.00	52.80	43.00	11.50	4.00	1662	001-38 O1	EV CS R 316 FDA
38.00	0380	57.10	35.00	52.80	35.00	10.50	0.50	1663	BS2-38 O1	EV CS R 316

VULCAN® SEALS TO SUIT INOXPA® PUMPS

Type 50 Seals to suit Prolac® Series pumps

EV P H S 316 FDA

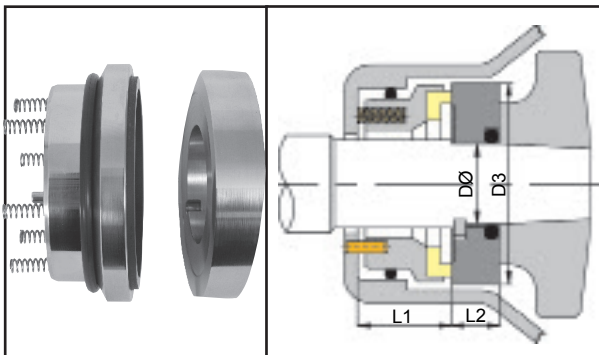

Vulcan manufacture and stock Type 50 stationary multi-spring seals, to suit Inoxpa® Prolac® "S-" series pumps, with single or tandem seal arrangements. With stationary seals like the Type 50, the coils are on the stationary and the rotary is a counter-ring. Pumps with flushed seal chambers use tandem seals, with the Vulcan Type 50 in the impeller position, and a standard Vulcan Type 1688 in the outer flush water position. Dimensions for the Type 1688 can be found in the Wave-Spring Seals section.

SHAFT SIZE DØ	SIZE CODE	D3	L1	L2
0.625	0158	44.50	26.00	10.50
1.000	0254	53.50	26.00	10.00
1.500	0381	74.00	31.00	15.50

TYPE 1683 SEALS TO SUIT INOXPA® SLR® SERIES LOBE ROTOR PUMPS

V P 316

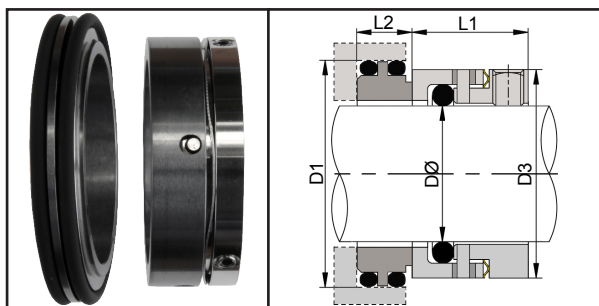

Vulcan manufacture and stock Type 1683 wave-spring O'-Ring mounted seals with bi-elastomeric seats, to suit Inoxpa® SLR® series lobe-rotor pumps. As with the majority of lobe rotor designs, two seals are required for each pump.

SHAFT SIZE DØ	SIZE CODE	D1	D3	L1	L2
28.00	0280	45.00	39.00	19.10	12.00
35.00	0350	53.00	45.50	19.10	12.00
50.00	0500	70.00	63.50	23.00	12.00
65.00	0650	90.00	82.30	25.80	14.00

VULCAN® TYPE 1651 SEALS TO SUIT JABSCO® PUMPS

N P 304 FDA

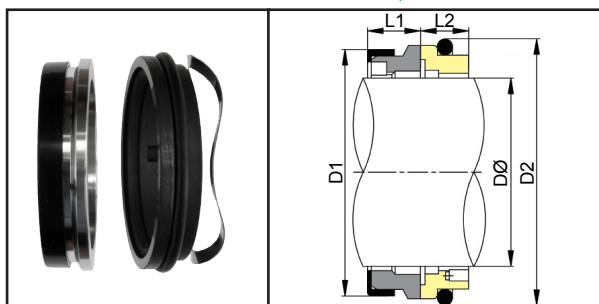

Vulcan manufacture and stock Type 1651 face sets to suit I.T.T. Jabsco® Hy-line® lobe-rotor pumps. Vulcan also offers other seals to suit common I.T.T. Jabsco® O.E.M. equipment, please contact us for details.

SHAFT SIZE DØ	SIZE CODE	D1	D2	L1	L2	O.E.M. PUMP MODEL
1.000	0254	37.00	38.00	11.10	12.30	LH 32, 34 & 42
1.375	0349	48.00	51.50	11.50	12.50	LH 44, LH 52
1.875	0476	60.50	64.50	12.70	13.70	LH 62, LH 64